



Service Bulletin

Reinforcement Plate Installation on aircraft SB-ASTM-CTLS-14

Repeating Symbols:

Please pay attention to the following symbols throughout this document emphasizing particular information.

- ▲ **Warning:** Identifies an instruction, which if not followed may cause serious injury or even death.
- **Caution:** Denotes an instruction which if not followed, may severely damage the aircraft or could lead to suspension of warranty.
- **Note:** Information useful for better handling.

1 Planning Information

1.1 Affected Aircraft

Type: CT
 Model: CTLS-LSA/CTLSi-LSA/CTLSst-HL-LSA
 Including EASA PtF CTLS-LSA/CTLSi-LSA
 Serial Number: Not limited
 Applicable Countries: All Countries

1.2 Concurrent Documents

- none -

1.3 Reason

The existing design of the pilot harness attachment (KF 2510 1000_01) meets all applicable certification requirements. An unusual event in service lead Flight Design to review the original testing protocol which was found to be correct. Retesting using a period airframe also found the design to meet all requirements with the required margins. However, to ensure an additional safety factor of the structure, it was decided to further strengthen the design of all CTLS series pilot harness attachments using these simple reinforcement plates.

1.4 Subject

Installation of Reinforcement Plate in upper attachment points of 4-point Harnesses.

1.5 Compliance

Compliance must be shown latest within 6 months following the issue date of this Bulletin, or at the next annual inspection of the aircraft, whichever comes first.

**Flight Design general aviation GmbH**Am Flugplatz 3, D-99820 Hörselberg Hainich,
Airfield Eisenach-KindelWeb: www.flightdesign.com; Phone: +49 36920 7530-10E-mail: airworthiness@flightdesign.com**SB-ASTM-CTLS-14 , Revision 00**Date of Initial Publication: **20-Mar-2019**
Publication Date of this Revision: **20-Mar-2019**

▲ Warning: Non-compliance with these instructions could result in further damages, personal injuries or death.

1.6 Approval

This SB is approved by the aircraft manufacturer i.a.w. ASTM F2483 for conduct on damaged aircraft as defined in 1.1. Subsequent to complete and correct conduct of this SB the aircraft being repaired will still meet the requirements of the applicable ASTM design and performance specification subsequent to the repair.

1.7 Type of Maintenance

Line

1.8 Personnel Qualifications

For National maintenance and inspection regulations as applicable for maintenance, assembly of aircraft systems, apply.

Task Specific: Can be completed only by a responsible individual with experience in assembly of aircraft systems.

1.9 Release to Service

Conduct of this SB must be inspected by an aircraft inspector according to the national applicable regulations for the country of registry of the aircraft.

Conduct of this SB must be logged in the aircraft log book with date and signature of the responsible Person according to national regulations.

Confirmation of Completion of this SB (chapter 4.2) has to be submitted to Flight Design.

1.10 Weight and Balance

- none -

1.11 References**1. Drawings:**

- none -

2. Documents:

- none -

1.12 Contact Details

For further information on conduct of this SB, or to report any Safety of Flight or Service Difficulty issues contact your Distributor responsible for your country. Your Distributor can be located via the Flight Design general aviation website: www.flightdesign.com under "Dealer Location".

In cases where the local distributor is not known or available contact Flight Design general aviation GmbH directly: customer.care@flightdesign.com

Specific contact in USA:

**Flight Design general aviation GmbH**Am Flugplatz 3, D-99820 Hörselberg Hainich,
Airfield Eisenach-KindelWeb: www.flightdesign.com; Phone: +49 36920 7530-10E-mail: airworthiness@flightdesign.com**SB-ASTM-CTLS-14 , Revision 00**Date of Initial Publication: **20-Mar-2019**Publication Date of this Revision: **20-Mar-2019**

Flight Design USA

P.O. Box 325 South Woodstock, CT 06267

Tel: 860 963 7272 / Fax: 860 963 7152

Web: www.flightdesignUSA.comE-Mail: airworthiness@flightdesignUSA.com

In cases where the local distributor is not known or available contact Flight Design general GmbH directly: airworthiness@flightdesign.com.

1.13 Disclaimer

This Service Bulletin has been generated with utmost care. Nevertheless, errors and misunderstandings can never be fully excluded. In case of any doubts the applicant of this Service Bulletin is requested to contact Flight Design immediately to clarify the issue.

2 Resources**2.1 Workshop Conditions**

- none -

2.2 Parts

- Reinforcement Plate (KF 2510 1003) - 2 pcs.
- Screw, countersunk DIN7991 M6x30-10.9-IH4-(A2K) - 4 pcs.
Part Number – C9996218
- Self-locking nut DIN 985-M6, regular - 4 pcs.
Part Number – C9996334
- Washer DIN 9021-6.4mm VZ - 4 pcs.
Part Number – C9996565

2.3 Materials

- Paint Marafkor TK 36 red (or equivalent torque stripe).

2.4 Tools

- Torque wrench 2-25 Nm with 10 mm head.
- Hand drill.
- Drill bit 6 mm.
- Allen key 4 mm.

2.5 Special tools

- none -

2.6 Manpower

The described task can be performed within approximately 1 hour (working time).



The working time includes:

- Installation of reinforcement plates

2.7 Cost

Check with your Flight Design service station for applicable spare part prices.

3 Instructions

- **Note:** Before maintenance, review the entire documentation to make sure you have a complete understanding of the procedure and requirements

3.1 General

This chapter provides extended explanations for the installation of reinforcement plate.

3.2 General Procedures

This chapter provides extended explanations for the reinforcement plate installation step.

3.3 Detailed Procedure

3.3.1 Uninstall upper attachment point of Pilot Safety Belts.



Fig. 3-3-1-1 (View from luggage compartment)



Fig. 3-3-1-2 (View from cabin)

3.3.2 Install the Reinforcement Plate from baggage compartment side.

1. Position the plates according to the sketch on the frame. Mark the hole position. In case the plate overlaps with the parachute rescue system bracket attachment, mark and cut out a notch or trim the plate to give the correct placement. See Fig. 3-3-2-1.
2. Drill the 6 mm holes according to the markings.
3. Make a test installation and verify that the plate has correct position and a minimized gap to the frame.
4. Make final installation according to the Sketch 1.

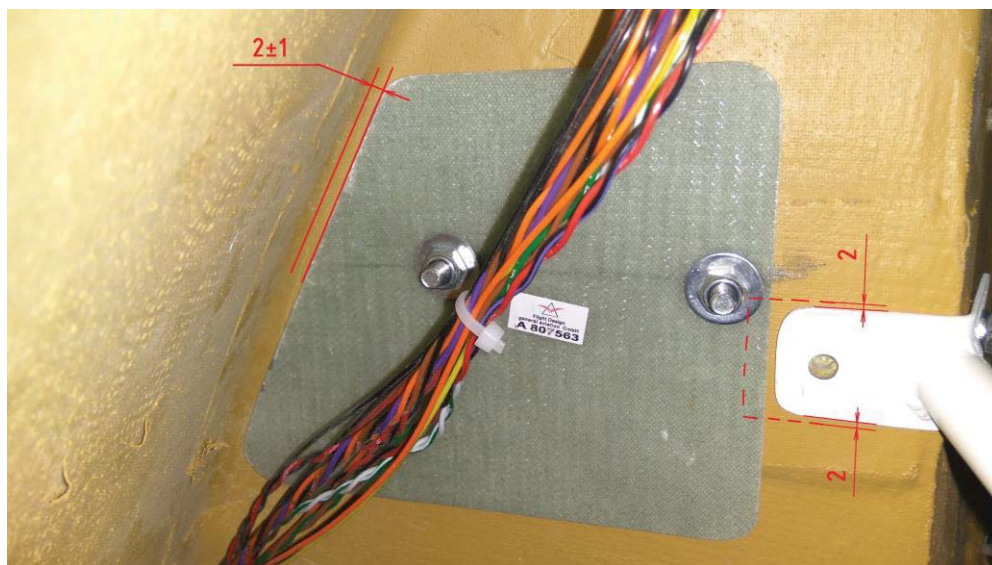
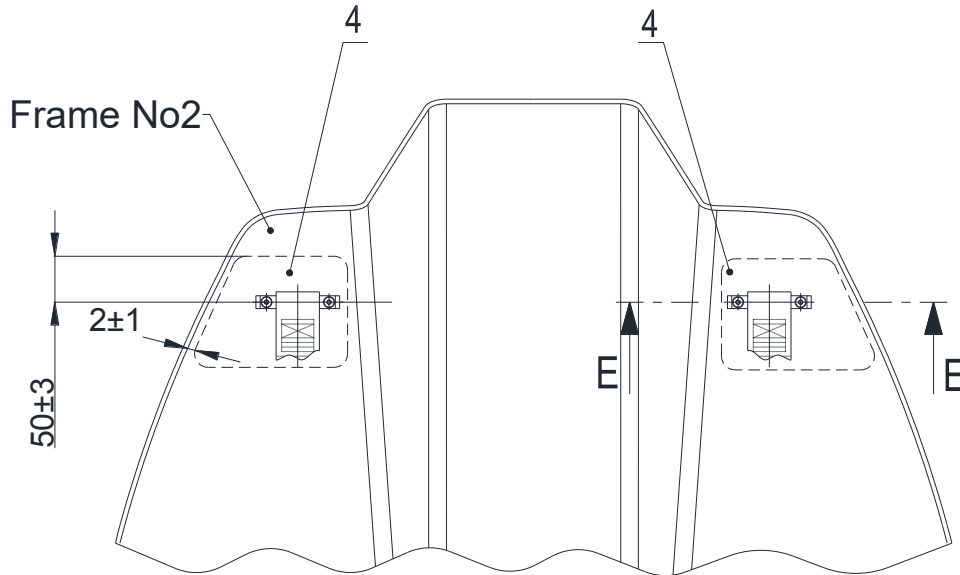
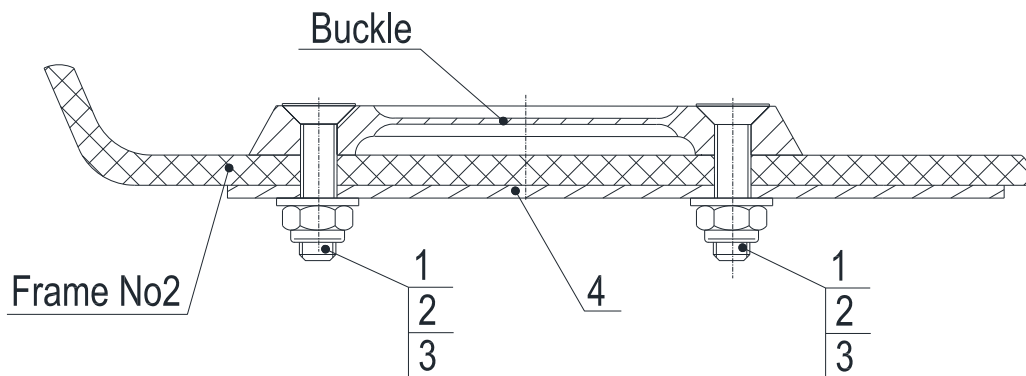

Fig. 3-3-2-1.



E-E

For 2 places



Sketch 1

1 - Screw, countersunk DIN7991 M6x30-10.9-IH4-(A2K) - 4 pcs.

2 - Washer DIN 9021-6.4mm VZ - 4 pcs.

3 - Self-locking nut DIN 985-M6, regular - 4 pcs.

4 - Reinforcement Plate - 2 pcs.

Mark all bolt-nut connections with "Paint Maraflor TK 36 red" or equivalent torque stripe.

Tightening torque nuts: 9Nm.

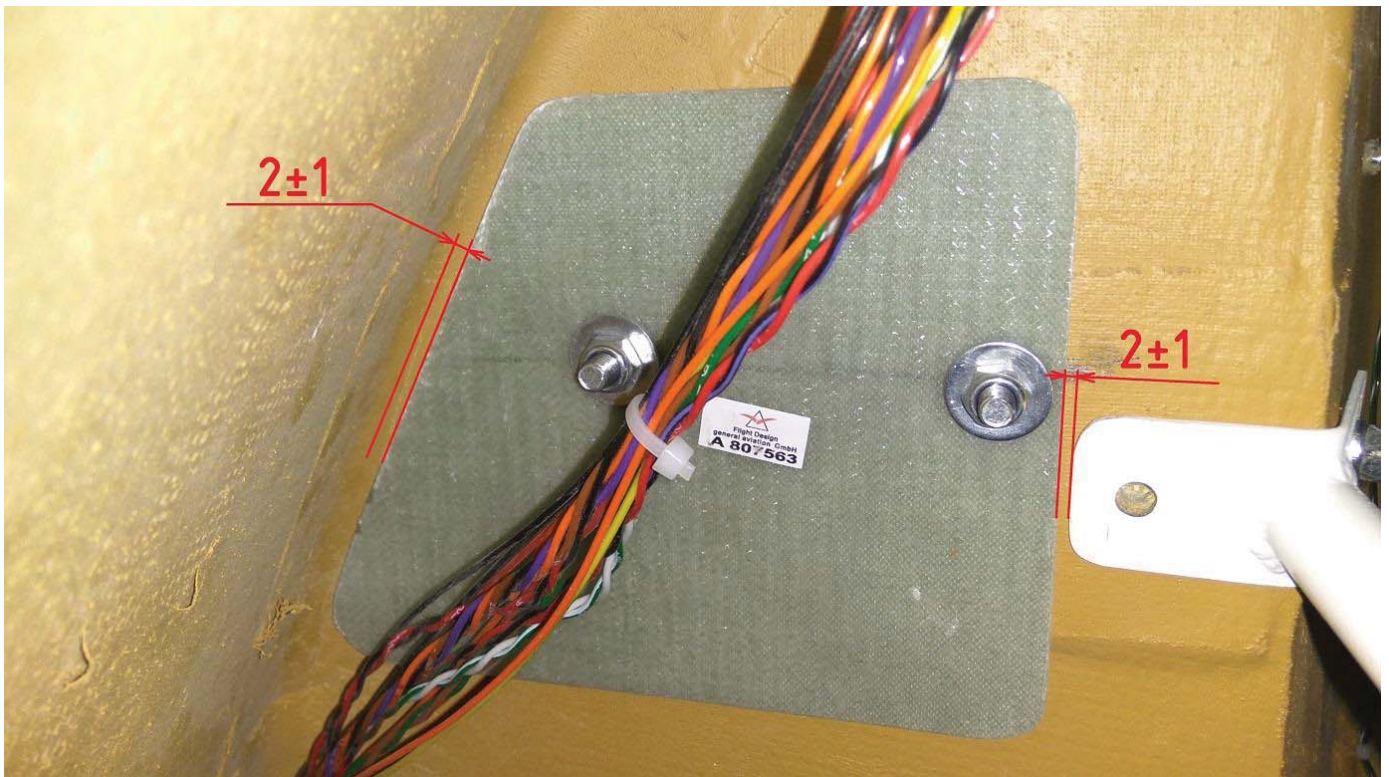

Fig. 3-3-3

3.4 Documentation

Conduct of this SB must be logged in the aircraft log book with date and signature of the responsible Person conducting the SB. National regulations have to be considered.

4 Appendix

4.1 Changes to Previous Revision

Original Issue – no changes



Flight Design general aviation GmbH

Am Flugplatz 3, D-99820 Hörselberg Hainich,
Airfield Eisenach-Kindel

Web: www.flightdesign.com; Phone: +49 36920 7530-10

E-mail: airworthiness@flightdesign.com

SB-ASTM-CTLS-14 , Revision 00

Date of Initial Publication: **20-Mar-2019**

Publication Date of this Revision: **20-Mar-2019**

4.2 Feedback Template

This form has to be used to coordinate with Flight Design the required spare parts and to communicate the completion of the SB listed in the header of this page.

Submission can be done by mail, Fax or as scanned copy by e-mail to Flight Design general aviation GmbH (see header of this page) or to your national Flight Design Distributor who will forward the information for you.

Information to obtain spare parts

Aircraft Type:

CT

Model:

CT__

Serial Number:

Aircraft Owner, Name and Address:

The reinforcement plates kit is required

Yes

No

Confirmation of Completion

Conduct of this SB has been done at the following workshop:

Responsible Mechanic:

Date: _____

Location: _____

Signature: _____

Warning:

As long as the form has not been submitted to Flight Design, this SB is considered not complied-with for the respective aircraft.